

## Working safely with cut-off machines

**Warning!**  
Read and follow all safety precautions in  
Instruction Manual – improper use can cause  
serious or fatal injury.

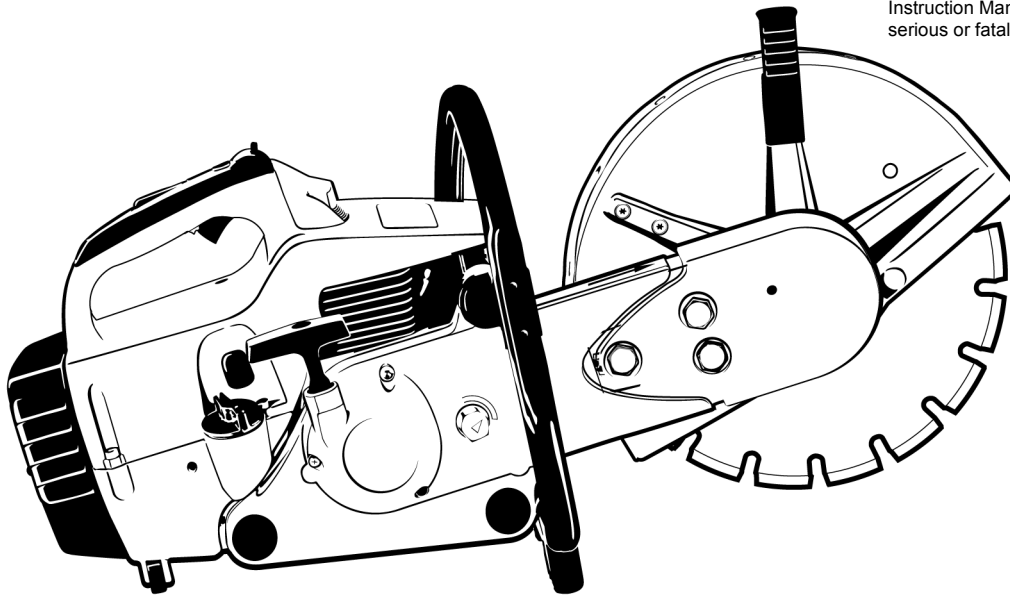



## Contents

Safety Precautions and Working Techniques	2
Sample applications	15
Cutting wheels	18
Composite resin cutting wheels	18
Diamond cutting wheels	18
Maintenance and Care	22
Main Parts	24

This manual contains the safety precautions and recommended cutting techniques outlined in STIHL instruction manuals for gasoline-powered cut-off machines. Even if you are an experienced cut-off machine user, it is in your own interest to familiarize yourself with the latest instructions and safety precautions regarding your cut-off machine.

Please note that the illustrations in the chapter "Main Parts of the Machine" in this manual show the cut-off machine STIHL Cutquik<sup>®</sup> TS 420.

Other cut-off machine models may have different parts and controls. You should therefore always refer to the instruction manual of your particular cut-off machine model.

Contact your STIHL dealer or the STIHL distributor for your area if you do not understand any of the instructions in this manual.



## Safety Precautions and Working Techniques



The use of any cut-off machine may be hazardous. Because a cut-off machine is a high-speed, fast-cutting power tool, special safety precautions must be observed to reduce the risk of personal injury and fire.



It is important that you read, fully understand and observe the following safety precautions and warnings. Read the instruction manual and the safety precautions periodically.

### **Warning!**

Careless or improper use of any cut-off machine may cause serious or fatal injury.

Have your STIHL dealer show you how to operate your cut-off machine.

Observe all applicable national, state and local safety regulations, standards and ordinances.

### **Warning!**

Your cut-off machine is for professional use only. Do not lend or rent your cut-off machine without the instruction manual. Be sure that anyone using it understands the information contained in this manual.

A first-time operator should obtain practical instruction before using the machine. Employers should establish a training program for operators of gasoline-powered, hand-held portable cut-off machines to assure safe operation of these machines. These safety precautions and warnings apply to the use of all current STIHL Cutquiks.

### **Warning!**

Use your cut-off machine only for authorized uses. For instance, it is not suitable for cutting wood or wooden objects. Misuse may result in personal injury or property damage, including damage to the machine.

### **Warning!**

Minors should never be allowed to use a cut-off machine. Bystanders, especially children, and animals should not be allowed in the area where a cut-off machine is in use. Never let the cut-off machine run unattended.

Different models may have different parts and controls. See the appropriate section of your instruction manual for a description of the controls and function of the parts of your model cut-off machine.

Safe use of a cut-off machine involves

1. the operator
2. the power tool
3. the use of the power tool.

## THE OPERATOR

---

### Physical Condition

You must be in good physical condition and mental health and not under the influence of any substance (drugs, alcohol, etc.) which might impair vision, dexterity or judgment. Do not operate a cut-off machine when you are fatigued. Be alert – if you get tired while operating your cut-off machine, take a break; tiredness may result in loss of control. Working with any cut-off machine can be strenuous. If you have any condition that might be aggravated by strenuous work, check with your doctor before operating a cut-off machine.

### **Warning!**

Prolonged use of cut-off machines (or other machines) exposing the operator to vibrations may produce whitefinger disease (Raynaud's phenomenon) or carpal tunnel syndrome. These conditions reduce the hand's ability to feel and regulate temperature, produce numbness and burning sensations and cause nerve and circulation damage and tissue necrosis. All factors which contribute to whitefinger disease are not known, but cold weather, smoking and diseases or physical conditions that affect blood vessels and blood transport, as well as high vibration levels and long periods of exposure to vibration are mentioned as factors in the development of whitefinger disease. In order to reduce the risk of whitefinger disease and carpal tunnel syndrome, please note the following:

- STIHL cut-off machines are equipped with an anti-vibration ("AV") system designed to reduce the transmission of vibrations created by the machine to the operator's hands. An AV system is recommended for those persons using cut-off machines on a regular or sustained basis.
- Wear gloves and keep your hands warm.
- Keep the AV system well maintained. A cut-off machine with loose components or with damaged or worn AV elements will tend to have higher vibration levels.
- Maintain a firm grip at all times, but do not squeeze the handles with constant, excessive pressure. Take frequent breaks.

All the above-mentioned precautions do not guarantee that you will not sustain whitefinger disease or carpal tunnel syndrome. Therefore, continual and regular users should monitor closely the condition of their hands and fingers. If any of the above symptoms appear, seek medical advice immediately.

### **Warning!**

The ignition system of your unit produces an electromagnetic field of a very low intensity. This field may interfere with some pacemakers. To reduce the risk of serious or fatal injury, persons with a pacemaker should consult their physician and the pacemaker manufacturer before operating this tool.

### **Proper Clothing**

#### **Warning!**



To reduce the risk of injury, the operator should wear proper protective apparel.

Clothing must be sturdy and snug-fitting, but allow complete freedom of movement. Avoid loose-fitting jackets, scarfs, neckties, jewelry, flared or cuffed pants, unconfined long hair or anything that could become caught on any obstacles or moving parts of the unit. Wear overalls or long pants to protect your legs. Do not wear shorts.

#### **Warning!**

When cutting metal, a cut-off machine generates sparks that can ignite clothing. Most fabrics used in clothing are flammable – even flame-retardant fabrics will ignite at higher temperatures. To reduce the risk of burn injury STIHL recommends wearing clothing made of leather, wool, flame-retardant-treated cotton or a tightly woven, heavier cotton such as denim. Some flame-retardant synthetic fabrics are also suitable, but others such as polyester, nylon, rayon and acetate can melt during a fire into a tar-like matter that burns into the skin. Check the clothing manufacturer's instructions. Keep clothing free of oil, fuel, grease and other flammable substances.



Always wear gloves when handling the cut-off machine. Heavy-duty, nonslip gloves improve your grip and help to protect your hands.



Good footing is important in cut-off machine work. Wear sturdy boots with nonslip soles. Steel-toed safety boots are recommended.

#### **Warning!**

Loose objects may be thrown toward the operator by the cutting tool.



To reduce the risk of injury to your eyes never operate a cut-off machine unless wearing goggles or properly fitted safety glasses with adequate top and side protection complying with ANSI Z 87.1. Proper eye protection is a must.

Wear an approved safety hard hat to protect your head. Cut-off machine noise may damage your hearing. Always wear sound barriers (ear plugs or ear muffs) to help protect your hearing. Regular users should have their hearing checked regularly.

 **Warning!**



When wet cutting at the recommended flow rate is not utilized, the operator should always wear a respirator approved by NIOSH / MSHA for the material being cut to reduce the risk of serious or fatal respiratory illness. For additional details and warnings on this subject, see information under "Working Conditions" in this instruction manual.

## **THE POWER TOOL**

---

For illustrations and definitions of the parts of the cut-off machine, see the chapter "Main Parts."

 **Warning!**

Never modify a cut-off machine in any way. Only attachments supplied by STIHL or expressly approved by STIHL for use with the specific STIHL cut-off machine models are authorized.

Although certain unauthorized attachments are useable with the STIHL powerhead, their use may, in fact, be extremely dangerous.

## **Abrasive Wheels**

 **Warning!**

Before mounting the cutting wheel, make sure that the maximum operating wheel speed is above or equal to the spindle speed of your cut-off machine as provided in the specifications of this manual. A wheel that is not so rated may shatter or break and poses a threat of serious or fatal injury to the operator and other nearby persons.

Abrasive wheels for free-hand cutting are subjected to particularly high bending and compression stresses.

 **Warning!**

Unauthorized wheels may be more likely to shatter or break. Use only STIHL wheels or other authorized wheels with approved RPM ratings. Read and follow any additional safety precautions that accompany the wheel.

 **Warning!**



Inspect the abrasive wheel frequently and replace immediately if the abrasive wheel is cracked or warped.  
Cracked or warped

wheels may shatter or break and cause serious or fatal personal injury. Out-of-round or unbalanced abrasive wheels increase vibration and reduce the service life of the cut-off machine.

Unauthorized diamond abrasive wheels that utilize poor quality steel cores, that are not properly tensioned, or that have other design or manufacturing defects

may begin to wobble during use, which can cause wheel breakage. Such wobbling can also lead to a severe binding of the wheel in the kerf, that, under certain circumstances, can then result in serious or fatal injury from reactive forces. See the section entitled "Reactive Forces including Kickback." Never use a wheel that wobbles or that has ever wobbled. Even though such a wheel may temporarily cease to wobble, e.g., if run without load, it will always be prone to wobble again under certain conditions. Replace it immediately before further use.

Composite abrasive wheels are heat sensitive. Always store your cut-off machine in a place where a composite wheel is not exposed to direct sunlight or other sources of heat. Store spare composite wheels in a dry place where there is no risk of frost damage. Failure to follow these directions may cause the wheel to shatter or crack in use causing serious or fatal injury.

 **Warning!**



Never use circular saw blades, carbide tipped blades, rescue blades, wood-cutting blades or toothed blades of any nature. They can cause

severe personal injury from blade contact, thrown objects and / or reactive forces, including kickback. See section on "Reactive Forces." Your STIHL dealer stocks a range of special abrasive wheels for the many applications of the cut-off machine.

 **Warning!**

Use of the wrong abrasive wheel or the cutting of material for which the wheel was not designed may cause the wheel to shatter causing serious or fatal injury.

Only use the abrasive wheel approved for the type of material to be cut. There are different types of abrasive wheels, each specially marked. With respect to composite wheels, for example:

1. Stone  
Also can be used for concrete, masonry, reinforced concrete and brick cutting.
2. Steel  
Can be used for all ferrous metal cutting.
3. Asphalt  
Also can be used for aggregate concrete cutting.
4. Ductile iron  
Also can be used for certain grades of cast iron (SG 17-24), bronze and copper cutting.

For cutting composite materials please ask your STIHL dealer.

### **Diamond Abrasive Wheels**

Diamond abrasive wheels have a much better cutting performance than composite abrasive wheels. The diamond wheels are steel centered, and diamond particles are imbedded in their cutting edges.

They can be used for concrete, asphalt, natural stone, clay pipe, brick and the like.

They are not normally suitable for cutting metal or other materials.

Wet or dry cutting is possible. Water attachments are included with your STIHL cut-off machine. See the appropriate section of your instruction manual.

 **Warning!**

Do not remount a used diamond abrasive wheel without first inspecting for under-cutting, flatness, core fatigue, segment damage or loss, signs of overheating (discoloration) and possible arbor hole damage. See the chapter "Diamond Cutting Wheels." Check the wheel for cracks and make sure that no pieces have broken off the wheel before use.

Always fit the wheel so that the arrow on the wheel points in the direction of the rotation of the spindle.

## **THE USE OF THE POWER TOOL**

### **Transporting the STIHL Cutquik**

 **Warning!**

To reduce the risk of injury from unintended activation and / or contact with a moving wheel, always stop the engine before putting a cut-off machine down or carrying it. The abrasive wheel continues to rotate (coast down) for a short while after the throttle trigger is released (flywheel effect). Bring the wheel to a stop by lightly contacting the bottom of the wheel with a hard surface or wait until the wheel comes to a complete stop on its own. Carrying a cut-off machine with the engine running is extremely dangerous. Accidental acceleration of the engine can cause the wheel to rotate. Avoid touching the hot muffler.

By hand: When carrying your cut-off machine by hand, the engine must be stopped and the cut-off machine must be in the proper position. Grip the front handle and place the muffler at the side away from the body.

 **Warning!**

Always protect the cutting wheel from hitting the ground or any other objects. Damaged wheels may shatter and cause serious or fatal injury.

By vehicle: Properly secure your cut-off machine to prevent turnover, fuel spillage and damage to the cut-off machine. Never transport with cutting wheel mounted. A wheel damaged

during transportation may shatter during operation and cause serious personal injury.

## Fuel

Your STIHL power tool uses an oil-gasoline mixture for fuel (see the chapter on "Fuel" of your instruction manual.)

### Warning!



Gasoline is an extremely flammable fuel. If spilled and ignited by a spark or other ignition source, it can cause fire and serious burn injury or

property damage. Use extreme caution when handling gasoline or fuel mix. Do not smoke or bring any fire or flame near the fuel or the power tool. Note that combustible fuel vapor may escape from the fuel system.

### Warning!

Dust may collect on the powerhead, especially around the carburetor, and may absorb gasoline resulting in danger of fire. Clean dust from the powerhead regularly.

## Fueling Instructions

### Warning!

Fuel your power tool in well-ventilated areas, outdoors. Always shut off the engine and allow it to cool before refueling. Gasoline vapor pressure may build up inside the fuel tank depending on the fuel used, the weather conditions and the tank venting system.

In order to reduce the risk of burns and other personal injury from escaping gas vapor and fumes, remove the fuel filler cap on your power tool carefully so as to allow any pressure build-up in the tank to release slowly. Never remove the fuel filler cap while the engine is running.

Select bare ground for fueling and move at least 10 feet (3 m) from the fueling spot before starting the engine. Wipe off any spilled fuel before starting your machine.

### Warning!



Check for fuel leakage while refueling and during operation. If fuel leakage is found, do not start or run the engine until the leak is fixed and

any spilled fuel has been wiped away. Take care not to get fuel on your clothing. If this happens, change your clothing immediately.

### Warning!

If fuel gets spilled on clothes, especially trousers, it is very important to change clothes immediately. Do not rely upon evaporation. Flammable quantities of fuel may remain on clothes after a spill for longer than expected. Cutting metal with a cut-off machine when clothes are wet or damp from gasoline is extremely dangerous, as the operator's clothes might catch fire and cause serious or fatal injury.

### Warning!

An improperly tightened fuel cap can loosen or come off and spill quantities of fuel.

Different cut-off machines may be equipped with different fuel filler caps:

#### Bayonet Fuel Filler Cap

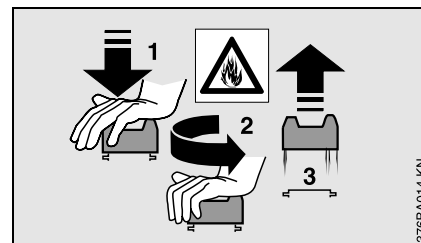

Never use a tool to open or close the bayonet fuel filler cap, as this could damage the cap and cause fuel to leak out.

The bayonet fuel filler cap must be closed with care after refuelling.

### Fuel Filler Cap with Screw Thread



Tighten the fuel filler cap as securely as possible after refuelling.

This reduces the risk of the cap working loose due to engine vibrations and fuel leaking out.

### Warning!

Never attempt to force the cap open by using a tool. It may damage the cap and allow fuel to leak.

Before use, make sure that the fuel cap has been properly tightened and any spilled fuel wiped away. Check for fuel leakage while refueling and during operation. If a fuel leak is suspected, do not start or run the engine until the leak is fixed and spilled fuel has been wiped away.

### Before Starting

For assembly, follow the procedure described in the appropriate section of your instruction manual.

Never operate a cut-off machine that is damaged, improperly adjusted or not completely and securely assembled. Check machine that it is ready for proper operation.

Keep the handles dry, clean and free of oil and fuel.

### Warning!

Before operation of your cut-off machine, be sure the controls (e.g. throttle trigger, throttle trigger lockout, stop switch) and the safety devices are working properly, the carburetor idle and maximum speed are correctly adjusted, the wheel is properly mounted, and the wheel guard is in place and securely fastened to your unit. All wheels should be carefully inspected for good condition before mounting.



Adjust the wheel guard so that sparks, dust and cut material are deflected away from the operator, and cannot reach flammable surroundings. See section "Operating Instructions" of your instruction manual.

### Warning!

Check that the spark plug boot is securely mounted on the spark plug – a loose boot may cause arcing that could ignite combustible fumes and cause a fire.

Proper tensioning of the ribbed V-belt is important. In order to avoid an incorrect setting, the tensioning procedure must be followed as described in your manual. Always make sure the hexagonal collar nuts for the cast arm are tightened securely.

Check ribbed belt tension after one hour of operation and correct if necessary.

### Starting

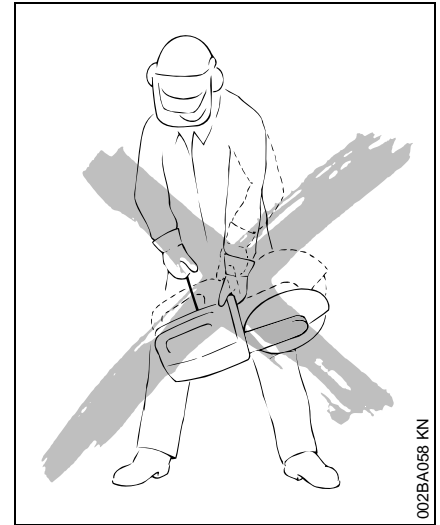

### Warning!

Your cut-off machine is a one-person tool. Do not allow other persons to be near a running cut-off machine. Start and operate your cut-off machine without assistance. For specific starting instructions, see the appropriate section of your instruction manual.

Do not drop start. This method is very dangerous because you may lose control of the cut-off machine. Place the cut-off machine on firm ground or other solid surface in an open area. Maintain good balance and secure footing. Be absolutely sure that the cutting wheel is clear of you and all other obstructions and objects, including the ground. When the engine starts at starting-throttle, engine speed will be fast enough for the clutch to engage the belt pulley and turn

the wheel. Never attempt to start the cut-off machine when the abrasive wheel is in a cut.

Once the engine has started, immediately blip the throttle trigger, which should release the starting throttle lock and allow the engine to slow down to idle.

### **Warning!**

When you pull the starter grip, do not wrap the starter rope around your hand. Do not allow the grip to snap back, but guide the starter rope slowly back to permit the rope to rewind properly. Failure to follow this procedure may result in injuries to hand or fingers and may damage the starter mechanism.

### **Important Adjustments**

At correct idle speed, the wheel should not turn. For directions to adjust idle speed, see the appropriate section of your instruction manual.

### **Warning!**

Do not use a cut-off machine with incorrect idle speed adjustment. The rotating wheel may cause injury. If you cannot obtain the correct setting, have your STIHL dealer check your cut-off machine and make proper adjustments or repairs.

### **Working Conditions**

Operate the cut-off machine under good visibility and daylight conditions only.

Wearing of hearing protection reduces sound perception. Be alert not to miss voice signals from co-workers. Keep within calling distance to other persons who may assist in case of emergency.

### **Warning!**



As soon as the engine is running, this product generates toxic exhaust fumes containing chemicals, such as unburned hydrocarbons (including benzene) and carbon monoxide, that are known to cause respiratory problems, cancer, birth defects, or other reproductive harm. Some of the gases (e.g. carbon monoxide) may be colorless and odorless. To reduce the risk of serious or fatal injury / illness from inhaling toxic fumes, never run the machine indoors or in poorly ventilated locations. Ensure proper ventilation when working in trenches or other confined areas.

### **Warning!**

Use of this product to cut masonry, concrete, metal and other materials can generate dust and fumes containing chemicals known to cause serious or fatal injury or illness, such as respiratory disease, cancer, birth defects or other reproductive harm. If you are unfamiliar with the risks associated with the particular material being cut, review the material safety data sheet and / or consult your employer, the material manufacturer / supplier, governmental agencies such as OSHA and NIOSH and other sources on hazardous materials. California and some other authorities, for instance, have published lists of substances known to cause cancer, reproductive toxicity, etc. Control dust and fumes at the source where possible.

In this regard use good work practices and follow the recommendations of the manufacturer / supplier, OSHA / NIOSH, and occupational and trade associations. A water attachment kit is provided with your cut-off machine and should be used to reduce dust whenever wet cutting is feasible. For dust suppression purposes, the flow rate should be at least 0.6 liters (20 fl.oz) of water per minute. If wet cutting at the recommended flow rate is not utilized, the operator and any bystanders should always wear a respirator approved by NIOSH / MSHA for the material being cut. See the section on "Respiratory Protection" in the chapter "Sample Applications" in the instruction manual. Even if wet cutting at the recommended flow rate, an operator who is actively cutting for more than two hours in one

day should wear at least a NIOSH-approved disposable respirator. Consult and follow any federal, state or local laws or regulations with respect to dry and wet cutting.

**Warning!**

Cutting masonry, concrete and other materials with silica in their composition may give off dust containing crystalline silica. Silica is a basic component of sand, quartz, brick clay, granite and numerous other minerals and rocks. Repeated and / or substantial inhalation of airborne crystalline silica can cause serious or fatal respiratory diseases, including silicosis. In addition, California and some other authorities have listed respirable crystalline silica as a substance known to cause cancer. When cutting such materials, always follow the respiratory precautions mentioned above.

**Warning!**

Breathing asbestos dust is dangerous and can cause severe or fatal injury, respiratory illness or cancer. The use and disposal of asbestos-containing products have been strictly regulated by OSHA and the Environmental Protection Agency. Do not use your cut-off machine to cut or disturb asbestos, asbestos-containing products, or products such as pipes which are wrapped or covered with asbestos insulation. If you have any reason to believe that you might be cutting asbestos, immediately contact your employer or a local OSHA representative.

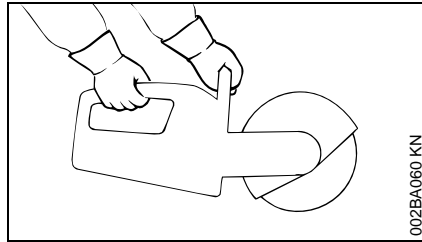

**Warning!**

Your STIHL cut-off machine is designed for hand-held use or operation on a cut-off machine cart. Cutting with your cut-off machine resting on the ground or other surface can cause excessive wear to the bracket designed to protect the bottom of the tank housing. Loss of fuel and personal injury from fire may result. Replace damaged or badly worn brackets immediately.

Grip: Never use the cut-off machine with one hand. Always hold the cut-off machine firmly with both hands when the engine is running. Place your left hand on front handle bar and your right hand on rear handle and throttle trigger. Left-handed users should follow this instruction too.

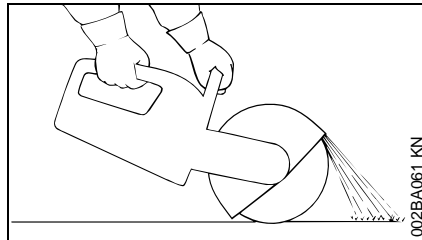

Wrap your fingers tightly around the handles, keeping the handles cradled between your thumbs and forefingers.

Make sure your cut-off machine handles and grip are in good condition and free of moisture, pitch, oil, fuel mix or grease.

Never touch a rotating wheel with your hand or any part of your body.

**Warning!**

Clear the area where you are working. Avoid stumbling on obstacles and watch out for holes or ditches. Be extremely cautious when working on slopes or uneven ground. Take extreme care in wet and freezing weather (rain, snow, ice.)

**Warning!**

Never operate the cut-off machine with the starting-throttle lock engaged as this does not permit proper control of the speed of the unit and may lead to serious injury.

**Warning!**



Sparks from cutting metal can burn or cause clothing to catch fire. Always direct sparks away from the operator or any flammable surroundings. Never cut metal while standing on a flammable surface, such as wood or tar paper. Where there is a risk of fire, have appropriate fire extinguishing equipment readily available.

 **Warning!**

To reduce the risk of injury from fire, do not cut into any pipe, drum or other container without first ensuring that it does not contain a volatile or flammable substance.

 **Warning!**

When cutting into existing walls, floors or similar structures, be alert for hidden hazards such as electrical cables, water and gas pipes and flammable substances. Make sure that power, water and gas have been shut off and pipes drained before starting to cut.

### Operating Instructions

 **Warning!**

The wheel guard is adjustable. It is extremely important that the wheel guard is in place and set to suit the type of work and your stance. The guard should always be adjusted so that the user is not endangered by particles of the material being cut, sparks or pieces of damaged wheels either directly or by ricochet. Failure to follow this instruction could result in serious or fatal injury.

 **Warning!**

Your cut-off machine is equipped with a wheel guard limit stop that restricts the opening of the wheel guard. To reduce the risk of injury from wheel contact and / or reactive forces and to avoid damaging the guarding system, never attempt to pull the adjusting lever past the limit stop.

 **Warning!**

Always check the wheel before use and after unintentionally striking any object; frequently check it during use when it is stopped. Look for cracks and make sure that it is undamaged and in good condition and that no pieces have broken off. See sections on "Abrasive Wheels" and "Reactive Forces" in this manual. Check the wheel guard for cracks. If you discover any breaks or cracks, fit a new guard before further use.

 **Warning!**

It is essential to determine the exact direction of the cut before applying the abrasive wheel to the work. Wheels are constructed for **radial** pressure only. **Lateral** pressure must be avoided. Hold the cut-off machine steady. To reduce the risk of serious or fatal injury, do not change the direction of the cut during the cut as this may produce a high torsional load on the abrasive wheel and may cause it to break or shatter.

 **Warning!**

Do not use abrasive wheels for rough grinding. Large bending stresses occur during such work, which may cause abrasive wheels to shatter or break and result in serious or fatal injury.

 **Warning!**

To reduce the risk of injury from shattered abrasive wheels:

1. Do not exceed the maximum operating speed marked on the wheel.
2. Do not use a wheel that has been dropped.
3. Test each new wheel immediately after installation for approximately one minute at maximum speed without cutting, making sure to keep bystanders away.
4. Do not cut any material for which the abrasive wheel is not authorized.
5. Do not grind on the side of the abrasive wheel.
6. Do not twist, thrust, knock or drop the machine. This can cause damage to the wheel.

To achieve a clean and efficient cut, pull the abrasive wheel across the work or move it "to and fro" in the cutting direction. Do not use force to push the abrasive wheel into the work.

Insert the wheel into the material only as deep as necessary to make the cut. To reduce the amount of dust created, do not cut all the way through stone and concrete materials – leave a thin piece uncut. For most such materials, this piece can be easily broken afterwards. Do not cock, jam or wedge the wheel in the cut.

Always stop the engine and be sure the wheel has stopped rotating before setting down the cut-off machine.

If a cut-off machine cart is used, sweep debris from the path of the wheels, as debris under one of the cart's wheels may cause flexing of the abrasive wheel. This could result in high frictional forces and thus greatly reduce the engine

power available for the actual cutting work. It could also damage the abrasive wheel.

STIHL recommends the use of the cart for longer cuts in a straight line.

### Wet Cutting with Abrasive Wheels

Before wet cutting, make sure water will not damage the floor or building.

#### Warning!

To reduce the risk of electrocution to you or bystanders, do not allow water or sludge to contact live electric wires.

#### Warning!

To reduce the risk of injury from wheel breakage when wet cutting with any composite wheel:

1. Make certain water does not flow on a wheel that is not running, since the wheel will absorb water, which will affect wheel balance.
2. Be certain water is applied to both sides of wheel, since uneven distribution can cause "one sided" wear.
3. After finishing work, run the cutting wheel at normal operating speed for about 3 to 6 seconds without water so that the remaining water is flung off.

#### Warning!

To reduce the risk of injury from wheel breakage when wet cutting with a composite wheel that is not specifically designed for wet cutting, never store and reuse such a wheel that has been used with water. Use these wheels up the same day.

### Reactive Forces including Kickback

#### Warning!



Reactive forces may occur at any time the cutting wheel on a cut-off machine is rotating. The powerful force used to cut through a workpiece can be reversed and work against the operator. If the wheel is slowed or stopped by frictional contact with any solid object or by a pinch or binding, reactive forces can occur instantly and may result in the operator losing control of the cut-off machine, which, in turn, may result in serious or fatal injury.

An understanding of the causes of these reactive forces may help you avoid loss of control. Reactive forces are exerted in a direction opposite to the direction in which the wheel is moving at the point of contact or of pinching / binding. If the wheel is slowed solely by frictional contact with a solid object, such as the workpiece, the resulting reactive forces are normally moderate and readily controllable by an operator who is holding the machine properly. If, however, the wheel is abruptly slowed or stopped by a pinch or severe bind, the reactive forces may be substantially

greater. The greater the force generated, the more difficult it will be for the operator to control the cut-off machine. Loss of control can result in severe personal injury or death.

### Pull-away, Climbing, Pinching and Rotational Kickback Forces

The most common reactive forces are pull-away and climbing. If the contact is at the bottom of the wheel, a cut-off machine will try to pull away from the operator (pull-away.) If the contact is at the front of the wheel, the wheel may attempt to climb the object being cut (climbing.)

Pinching occurs when the piece being cut closes on the wheel. A severe binding may also occur if the wheel is substantially sideloaded in the kerf or if an improper or damaged diamond wheel begins or ceases to wobble in the kerf. If the wheel is severely pinched or bound in the upper quadrant, the wheel may be instantly thrown up and back towards the operator with great force in a rotational kickback motion. Such kickback situations can and should always be avoided. Pinching of the wheel can be prevented by proper support of the workpiece. (See below.) Severe binding of the wheel can be prevented by proper cutting techniques, e.g., not sideloading the wheel, and by the use of properly designed, manufactured and maintained wheels.

## Reducing the Risk of Kickback Injury

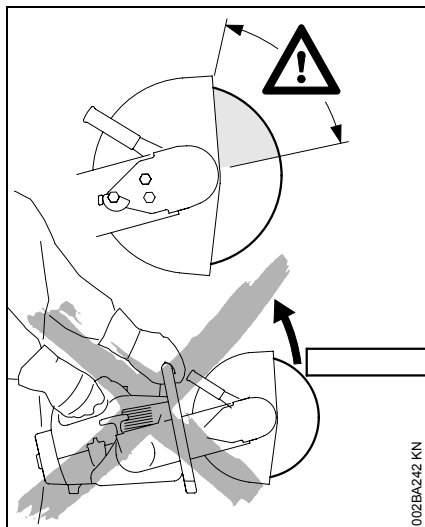

### **Warning!**

To reduce the risk of kickback injury, avoid cutting with the upper quadrant of the wheel where possible. Be especially cautious for a pinching or binding of the wheel in this area, which can cause severe reactive forces in a rotational kickback motion.

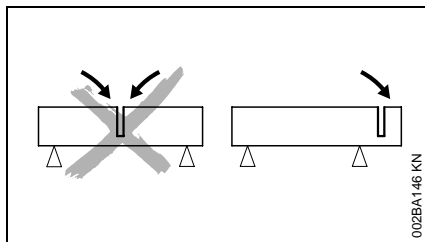

Be alert to potential movement of the workpiece or anything else that could cause the cut to close and pinch the wheel. In order to reduce the risk of

pinching, support the workpiece in such a way that the cut remains open during the cutting process and when the cut is finished (see illustration.) Never make a cut that results in a binding of the wheel. If you cannot properly support the workpiece, do not use a cutting-off machine to make the cut; select another tool or cutting technique that is not subject to kickback.

### **Warning!**

Be particularly alert when cutting a workpiece such as a pipe with a belled end or a pipe in a trench that, if not properly supported, can sag upon completion of the cut, creating a pinch not where you are actually cutting but, rather, at or near the top of the workpiece. If the pinch is in the upper quadrant of the abrasive wheel, kickback can result.

### **Warning!**

Use wet-cutting whenever feasible, since the water can act as a lubricant in a pinch situation and thus reduce the likelihood of reactive forces occurring and the energy of any such forces that do occur, making it easier to maintain control of the machine.

### **Warning!**

Use only cutting attachments authorized by STIHL. Use of non-STIHL-authorized wheels may be extremely dangerous. Many substandard diamond wheels, for instance, are available in the market. If they are not manufactured with the proper quality steel in their core, if they are not properly tensioned, or if other design or manufacturing defects exist, they may, e.g., begin to wobble during use. If a diamond wheel begins or ceases to wobble within the kerf, the change in the behavior of the wheel may cause a severe binding that can lead to loss of control and / or kickback. If the wheel you are using begins to wobble or has ever wobbled, discard it immediately. Although such a wheel may temporarily cease to wobble, e.g., if run without load, it will always be prone to wobble again under certain conditions.

Some other unauthorized diamond wheels are manufactured with abrasive material on their sides. Do not use such wheels, since the abrasive material may lead to increased reactive forces in a pinch situation.

### **Warning!**

Never use chipped abrasive wheels or circular saw blades, carbide-tipped blades, rescue blades or wood-cutting or toothed blades of any nature on a cut-off machine. The use of such wheels or blades will greatly increase the risk of loss of control and severe personal injury or death from reactive forces, since the chipped section of an abrasive wheel or the teeth of a saw blade may catch in the material being cut and generate substantially greater reactive forces, including rotational kickback.

Cut-off machines are designed for use with abrasive wheels in good condition only. Machines designed for use with wood-cutting or other toothed blades use different types of guarding systems that provide the protection necessary for those types of blades. Machines, such as a cut-off machine, that are designed for use with abrasive wheels require a different guarding system, which is not designed to provide protection against all dangers presented by circular saw blades, carbide-tipped blades, rescue blades or wood-cutting or toothed blades of any nature.

### **Warning!**

To reduce the risk of injury from loss of control from reactive forces, including kickback:

1. Hold the cut-off machine firmly with both hands.
2. Maintain good balance and footing at all times. Never cut while standing on a ladder.

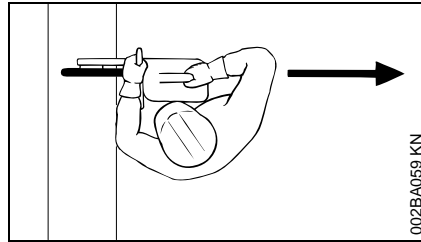

3. Position the cut-off machine in such a way that your body is clear of the cutting attachment. Avoid standing in direct line with the wheel. Never bend over the cutting attachment, especially when the guard is pulled back towards the top and there is a risk of reactive forces. (See illustration.)
4. Do not cut above shoulder height.
5. Use only STIHL-branded diamond and composite abrasive wheels. Never work with a diamond wheel that wobbles or that has ever wobbled or that is manufactured with abrasive material on its sides.
6. Do not cut wood or any other material for which the abrasive wheel is not authorized.
7. Never use circular saw blades, carbide-tipped blades, rescue blades, wood-cutting blades or toothed blades of any nature. Their use increases the risk of injury from blade contact, thrown tips and reactive forces, including kickback.
8. Begin cutting and continue at full throttle.
9. Do not overreach.
10. Never sideload a wheel in the kerf.
11. Use your cut-off machine for cutting only. It is not designed for prying or shoveling away any objects.
12. Be especially alert for reactive forces, including kickback, when cutting with the front and upper quadrant of the wheel. Never pull the top of the wheel guard back beyond the limit stop.
13. Be alert to shifting of the workpiece or anything that could cause the cut to close and pinch the wheel, especially in the upper quadrant. Support the workpiece in such a way that the cut remains open. Never make a cut that results in a binding of the wheel.
14. Use wet-cutting whenever feasible. In a pinch situation the water can act as a lubricant and reduce the energy of reactive forces.
15. Release the pressure on the cut-off machine as you reach the end of the cut. Too much pressure may cause the operator to lose control of the cut-off machine when the abrasive wheel completes the cut. The abrasive wheel may contact the operator or strike some foreign object and shatter.
16. Use extreme caution when reentering a cut and do not turn the wheel at an angle or push the wheel into the cut as this may result in a binding of the wheel.

### **Gyroscopic Forces**

Be alert for gyroscopic forces that are caused by the rapid spinning of the cut-off wheel. These forces result in

opposition to directional change, e.g., when the operator attempts to move the machine in a sideways direction.

### **Maintenance, Repair and Storing of the Cut-Off Machine**

---

**Maintenance, replacement, or repair of the emission control devices and systems may be performed by any nonroad engine repair establishment or individual. However, if you make a warranty claim for a component that has not been serviced or maintained properly or if nonapproved replacement parts were used, STIHL may deny warranty coverage.**

Never operate a cut-off machine that is damaged, improperly adjusted or not completely or securely assembled. Follow the maintenance and repair instructions in the appropriate sections of your instruction manual.

#### **Warning!**

Use only STIHL replacement parts for maintenance and repair. Use of parts manufactured by others may cause serious or fatal injury.

#### **Warning!**

Always stop the machine, make sure that the wheel is stopped, and remove the spark plug boot from the spark plug before doing any maintenance or repair work or cleaning the cut-off machine. Do not attempt any maintenance or repair work not described in your instruction manual. Have such work performed only at your STIHL servicing dealer.

Clean off grinding dust after finishing work. Tighten all nuts, bolts and screws except the carburetor adjustment screws after each use.

Do not clean your machine with a pressure washer. The solid jet of water may damage parts of the machine.

#### **Warning!**

Never test the ignition system with spark plug boot removed from spark plug or with unseated spark plug, since uncontained sparking may cause a fire.

#### **Warning!**

To reduce the risk of fire and burn injury, use only spark plugs authorized by STIHL. Always press spark plug boot snugly onto spark plug terminal of the proper size. (Note: If terminal has a detachable SAE adapter nut, it must be attached.) A loose connection between spark plug terminal and ignition wire connector in the boot may create arcing that could ignite combustible fumes and cause a fire. Keep spark plug clean, and make sure ignition lead is in good condition.

#### **Warning!**

Do not operate your cut-off machine if the muffler is damaged, missing or modified. An improperly maintained muffler will increase the risk of fire and hearing loss. Never touch a hot muffler or spill fuel or other flammable liquid over it. Burn injuries or fire will result. If your muffler was equipped with a spark-arresting screen to reduce the risk of fire (e. g. in the USA, Canada and Australia), never operate your cut-off machine if the screen is missing or damaged.

For any maintenance please refer to the maintenance chart and to the warranty statement near the end of the instruction manual.

Store wheels on a flat surface in a dry place, preferably at a constant temperature, where there is not a risk of frost. Do not store a cut-off machine with a wheel mounted on the machine. Store cut-off machine in a high or locked place, away from children.

Empty the fuel tank before storing for longer than a few days. Store fuel only in correctly labeled and approved containers. Avoid direct skin contact and do not inhale the gas vapors.

## Sample applications

### Most diamond cutting wheels are suitable for wet cutting

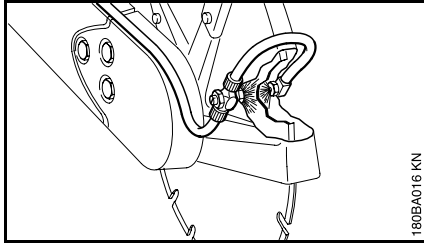

**Wet cut whenever feasible. It increases the service life and cutting speed of diamond cutting wheels.**

Ensure that the cutting wheel is generously supplied with water.

#### Wet cutting helps to suppress dust.

The water binds the dust.

The cutting wheel must be supplied with at least 0.6 liters water per minute.

**Wet cutting can reduce the energy of reactive forces.** In a pinch situation, the water can act as a lubricant.

### Water connection

- A water attachment kit is mounted on the machine for use with all types of water supply.
- A pressurized 10 liter water tank is available from STIHL for dust suppression.
- A water tank for mounting on the Cutquik cart is also available for dust suppression.

**Composite resin wheels can be used for dry cutting of metals or for wet or dry cutting of concrete, stone or masonry.**

### Composite resin wheels designed for dry cutting

Special procedures must be followed when wet cutting with a composite non-diamond wheel designed for dry cutting. See the section entitled "Wet Cutting with Abrasive Wheels" in the safety precautions of this manual. Wet cutting is generally not suitable for cutting metals.

### Composite resin wheels designed for wet cutting



Adjust water flow rate during cutting so it is sufficient to bind all the dust that occurs (at least 0.6 L/min).

If the water flow rate is too high, the cutting wheel may skim on the water surface in the cut and greatly reduce cutting performance. To avoid this, do not exceed a water flow rate of about 4 L/min.

Use water properly:

1. Be certain water is applied to both sides of wheel, since uneven distribution can cause one sided wear with possible wheel breakage.
2. Make certain water does not flow on wheel that is not running, since the wheel will absorb water and that will affect wheel balance.
3. After finishing work, run the cutting wheel at normal operating speed for about 3 to 6 seconds **without** water so that the remaining water is flung off.

### Water connection

- A water attachment kit is mounted on the machine for use with all types of water supply.
- A pressurized 10 liter water tank is available from STIHL for dust suppression.
- A water tank for mounting on the Cutquik cart is also available for dust suppression.

### Respiratory protection



#### Warning!

When wet cutting at the recommended flow rate is not utilized, the operator and any bystanders should always wear a respirator approved by NIOSH/MSHA for the material being cut. Even if wet cutting, an operator who is actively cutting for more than two hours a day should wear at least a NIOSH-approved disposable respirator.

## Points to be noted with diamond and composite resin cutting wheels

### Object to be cut

- Must be fully supported
- Must be secured so that it cannot roll or slip away
- Must be protected against vibration

### The cutting sequence

The cutting sequence is important when cutting openings and recesses, etc. The last cut must always be made in such a way that the cutting wheel cannot become bound and so that the user is not at risk of being injured by the part that has been cut off or out.

If applicable, leave small ridges of uncut material to hold the severed part in position. These ridges can subsequently be broken through.

A number of points must be decided before the part is finally severed:

- How heavy is the part?
- In which direction can it move after being severed?
- Is it under tension?

Helpers must not be put at risk of injury when the part is broken off or out.

## Cutting in several passes

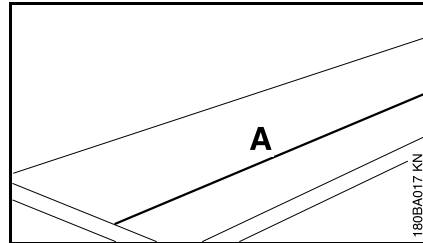

- Mark cutting line (A).

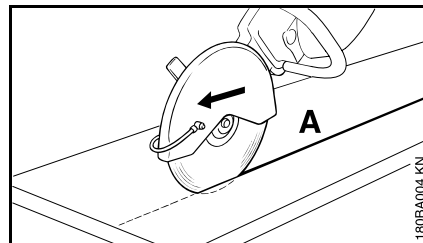

- Work along the cutting line. If corrections are necessary, always reposition the cutting wheel, taking care to ensure that it is not wedged. The cutting depth per pass should not exceed 5 to 6 cm (2" to 2 1/2"). Thicker material must be cut in several passes.

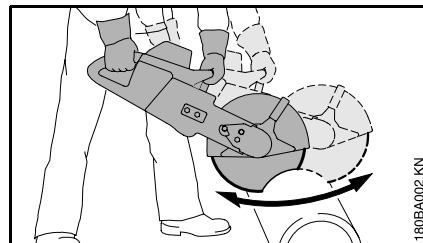

- Thick-walled workpieces should be cut with a uniform swinging movement, back and forth.

## Cutting slabs

- Place the slab securely on a non-slip surface.

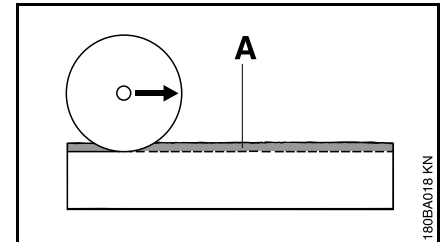

- Cut a guiding groove (A) along the marked line.

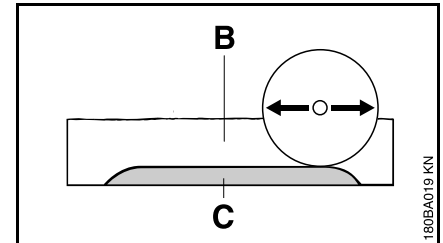

- Cut deeper into the parting cut (B) with uniform back-and-forth movements.
- Leave a ridge (C) of uncut material.
- Cut through the slab at the ends so the material does not chip.
- Then break the slab.

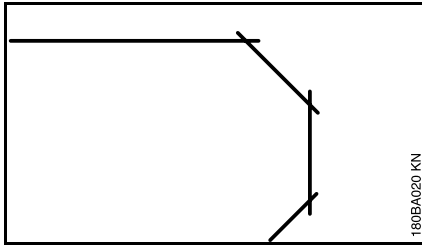

- Curves must be cut in several straight passes, taking care to ensure that the cutting wheel does not become wedged.

### **Cutting round and hollow workpieces**

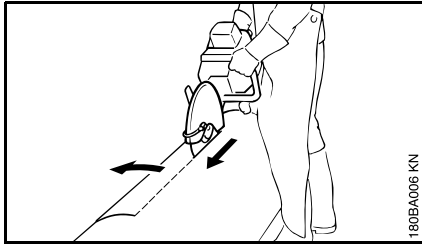

- Pipes and round objects, etc. must be secured so that they cannot roll.
- Avoid reinforcing elements, especially in the direction of the cut, when deciding on the cutting line.
- Cut a guiding groove along the marked line.
- Cut deeper into the parting cut with uniform back-and-forth movements. Advance the cutting wheel along the guiding groove at full cutting depth. Always reposition the cutting wheel, taking care not to wedge it, if the cutting direction has to be corrected slightly. If necessary, leave small ridges of uncut material to hold the

severed part in position. These ridges can subsequently be broken through.

### **Cutting shapes on pipes**

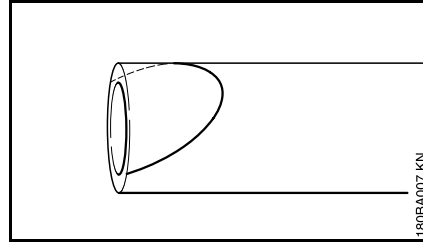

- Mark the cutting line.

### **Warning!**

Particular care and precision are required for free-hand cutting along such cutting lines. Avoid side-loading the wheel or causing it to bind.

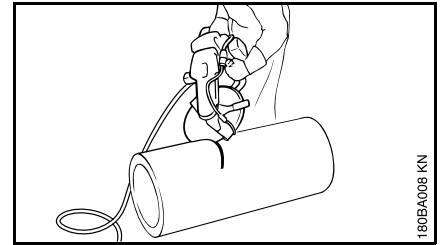

- Cut a guiding groove along the marked cutting line, starting at the top and moving out towards both sides.
- Cut into the pipe or round object, etc. at the ends of the cutting line so that the material does not chip.
- Cut deeper into the parting cut with uniform back-and-forth movements, starting at the top and moving out towards the sides. Advance the cutting wheel along the guiding groove at full cutting depth. Always reposition the cutting wheel afresh, taking care not to wedge it if the cutting direction has to be corrected slightly. If necessary, leave small ridges of uncut material to hold the severed part in position. These ridges can subsequently be broken through.

## Cutting wheels

Cutting wheels are exposed to extremely high loads especially during freehand cutting.

The cutting wheels, which have been developed by STIHL in cooperation with renowned manufacturers of abrasive wheels, are of high quality and tailored precisely to the respective intended use as well as the engine performance of the cut-off machine.

They are of consistently outstanding quality.

### Transport and storage

- Do not expose cutting wheels to direct sunshine or other thermal stresses during transport and storage
- Avoid jolting and impacts
- Stack cutting wheels flat on a level surface in the original packaging in a dry place where the temperature is as constant as possible
- Do not store cutting wheels in the vicinity of aggressive fluids
- Store cutting wheels in a frost-free place

## Composite resin cutting wheels

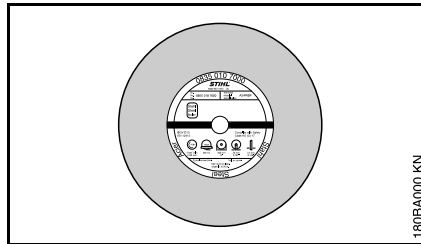

Economic benefit is improved and premature wear can be avoided by choosing and using the correct composite resin cutting wheel. The short name (e.g. "asphalt", "concrete")

- on the label and
- on the packaging (table with recommended uses)

can help to ensure the correct choice.

STIHL composite resin cutting wheels are suitable, depending on the version, for cutting the following materials:

- Asphalt
- Concrete
- Stone
- Ductile cast pipes
- Steel

STIHL composite resin cutting wheels cannot be used to cut railway tracks.

## Diamond cutting wheels

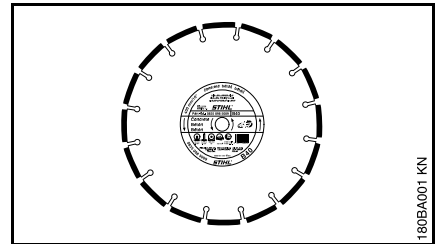

Economic benefit is improved and premature wear can be avoided by choosing and using the correct diamond cutting wheel. The short name (see following explanation)

- on the label and
- on the packaging (table with recommended uses)

can help to ensure the correct choice.

STIHL diamond cutting wheels are suitable, depending on the version, for cutting the following materials:

- Asphalt
- Concrete
- Stone (hard rock)
- Abrasive concrete
- Green concrete
- Clay bricks
- Clay pipes

Diamond abrasive wheels cannot be used to cut metal.

## Short names

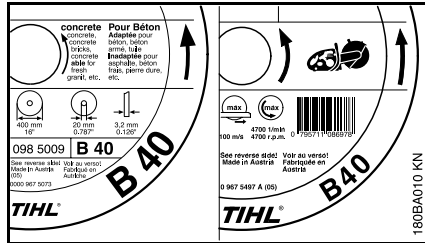

The short name is a combination of letters and numerals with up to four digits:

- The letters indicate the main area of use for the cutting wheel.

Letter	Main area of use
<b>A</b>	Asphalt
<b>B</b>	Concrete
<b>BA</b>	Concrete, Asphalt
<b>S</b>	Stone (rock)
<b>SB</b>	Rock, Concrete

- The numerals indicate the performance class of the STIHL diamond cutting wheel.

## Radial and axial run-out

A correctly mounted spindle bearing on the cut-off machine is essential for a long service life and efficient operation of the diamond cutting wheel.

Using a cutting wheel on a cut-off machine with defective spindle bearing can lead to axial and radial run-out.

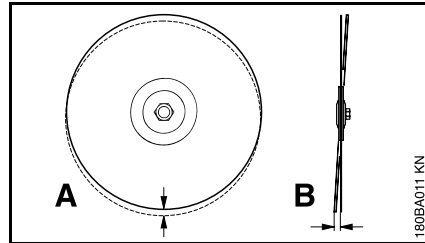

Excessive radial run-out (**A**) causes individual diamond segments to be overloaded and to overheat. This can in turn lead to stress cracking in the wheel core or to softening of individual segments.

Axial run-out or wobble (**B**) results in higher thermal stress and wider cuts.

## Troubleshooting

---

### Cutting wheel

Problem	Cause	Remedy
Frayed edges or tears, cut wanders out of line, increased wear at the sides of the segments	Radial or axial run-out	Consult a dealer <sup>1)</sup>
	Cutting wheel wobbles	Use a new cutting wheel
Frayed edges, cut wanders out of line, little or no cutting performance, sparking	Cutting wheel is blunt; built-up edges on cutting wheels for stone	Dress the cutting wheel for stone by briefly cutting in abrasive material; use a new cutting wheel for cutting asphalt
Poor cutting performance, high level of segment wear	Cutting wheel rotates in the wrong direction	Mount the cutting wheel with correct direction of rotation
Chipping or cracking in the wheel core and segments	Overload	Replace immediately with a new cutting wheel
Undercutting	Cutting in a material for which the wheel is not rated	Use a new cutting wheel; note the different cutting layers in different materials

<sup>1)</sup> STIHL recommends that a STIHL servicing dealer be consulted.

## Undercut

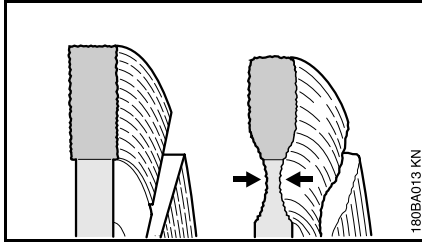

Undercutting is a wearing away of the steel core at or just below the diamond segments. When cutting road surfaces, do not cut through into the more abrasive ballast (gravel, crushed rock) below, as indicated by a light colored dust. This can cause excessive undercutting, resulting in wheel breakage and/or thrown segments.

### Warning!

Immediately replace a diamond wheel if the core has been severely undercut.

## Built-up edges, dressing

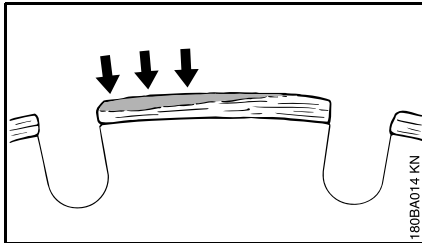

Built-up edges are identified by a pale grey deposit on the top of the diamond segments that clogs and blunts the segments.

Built-up edges can form:

- when cutting extremely hard material, such as granite,
- as a result of incorrect handling, such as applying excessive feed force,
- if extremely large sections are cut without a pendulum movement (back and forth in the cutting plane).

Built-up edges increase vibrations, reduce cutting performance and cause sparking.

Diamond cutting wheels must be "dressed" at the first sign of built-up edges. For this purpose, briefly cut a more abrasive material, such as sandstone, aerated concrete or asphalt.

Wet cutting helps to prevent the formation of built-up edges.

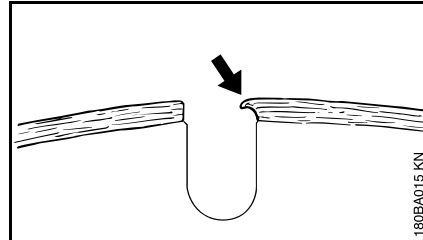

If you continue to use a cutting wheel with blunt segments, the segments may soften as a result of excessive heat built up. The wheel core will also overheat and lose its mechanical strength. This can lead to considerable stress, as clearly indicated by stress cracks and/or a wobbling movement of the cutting wheel.

### Warning!

Such cutting wheels may break apart or throw off segments during use, causing serious or fatal injury. Replace them immediately.

## Maintenance and Care

The following maintenance intervals apply in normal operating conditions. The specified intervals must be shortened accordingly when working for longer than normal or under difficult cutting conditions (extensive dust, etc.).		before starting work	at the end of work and/or daily	Whenever tank is refilled	Weekly	Monthly	Yearly	If faulty	If damaged	As required
Complete machine	Visual inspection (condition, leaks)	X		X						
	Clean		X							
Operating elements	Check operation	X		X						
Fuel pick-up body in fuel tank	test, check							X		
	Replace						X		X	X
Fuel tank	Clean					X				
Ribbed V-belt	Clean / retension					X				X
	Replace								X	X
Air filter (all filter components)	Replace	<b>Only if there is a noticeable loss of engine power</b>								
Cooling air intake slits	Clean		X							
Cylinder fins	Have them cleaned by a specialist dealer <sup>1)</sup>						X			
Spark arresting screen <sup>2)</sup> in muffler	test, check		X							
	Clean or replace									X
Water attachment	test, check	X						X		
	Have them maintained by a specialist dealer <sup>1)</sup>								X	
Carburetor	Check idle adjustment – abrasive wheel must not rotate	X		X						
	Readjust idle speed									X
Spark plug	Adjust electrode gap							X		
	Replace after 100 hours' operation									
All accessible screws, nuts and bolts (not adjusting screws)	Retighten		X							X

The following maintenance intervals apply in normal operating conditions. The specified intervals must be shortened accordingly when working for longer than normal or under difficult cutting conditions (extensive dust, etc.).		before starting work	at the end of work and/or daily	Whenever tank is refilled	Weekly	Monthly	Yearly	If faulty	If damaged	As required
Antivibration elements	test, check	X						X		X
	Have them replaced by a specialist dealer <sup>1)</sup>								X	
Abrasive wheel	test, check	X		X						
	Replace								X	X
Supports/rubber buffers (underneath the machine)	test, check		X							
	Replace								X	X
Safety information sticker	Replace								X	

<sup>1)</sup> STIHL recommends STIHL servicing dealers

<sup>2)</sup> present only in some countries

## Main Parts

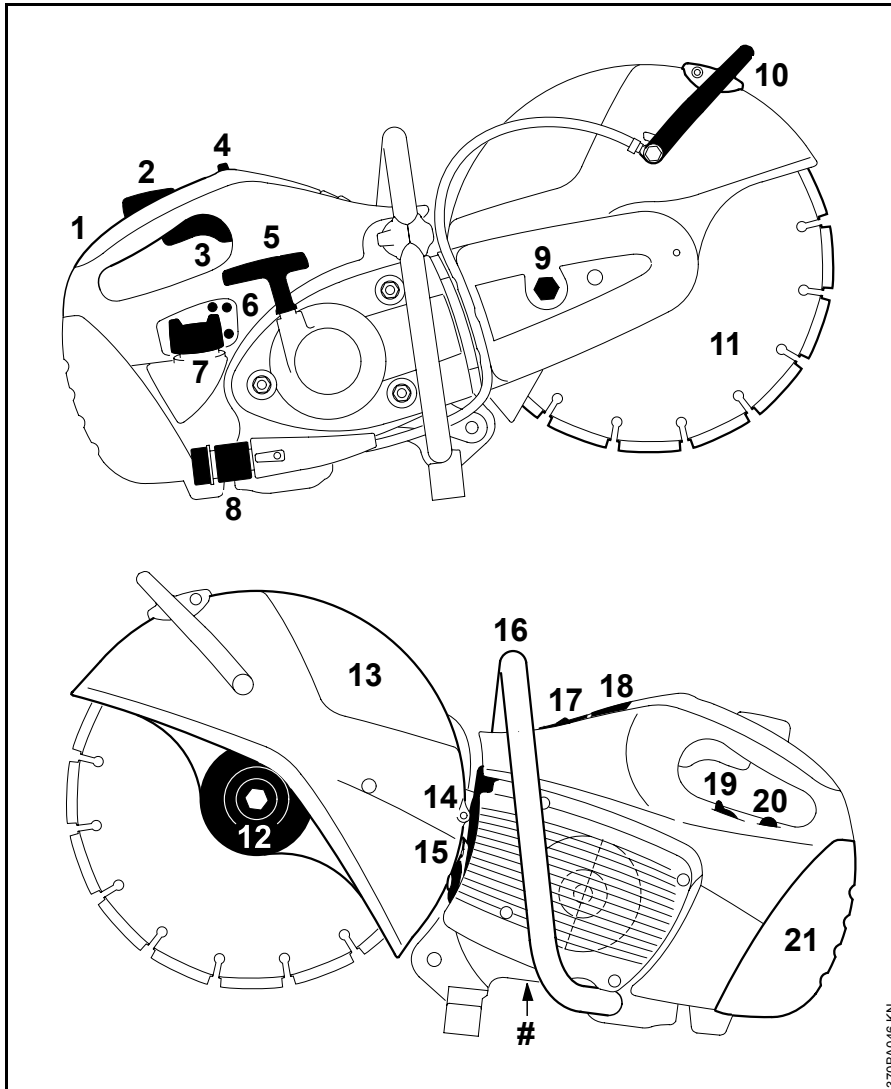

- 1 Rear Handle
- 2 Throttle Trigger Lockout
- 3 Throttle Trigger
- 4 Slide Control
- 5 Starter Grip
- 6 Carburetor Adjusting Screws
- 7 Fuel Filler Cap
- 8 Water Attachment
- 9 Tensioning Nut
- 10 Adjusting Lever
- 11 Abrasive Wheel
- 12 Front Thrust Washer
- 13 Guard
- 14 Muffler
- 15 Spark Arresting Screen
- 16 Front Handle
- 17 Decompression Valve
- 18 Cap for Spark Plug Boot
- 19 Choke Lever
- 20 Fuel Pump
- 21 Filter Cover
- # Serial Number

3.70BAQ46 KN

## Definitions

---

- 1 Rear Handle**  
The support handle for the right hand.
- 2 Throttle Trigger Lockout**  
Must be depressed before the throttle trigger can be activated.
- 3 Throttle Trigger**  
Controls the speed of the engine.
- 4 Slide Control**  
For starting throttle, run and stop. Keeps the throttle partially open during starting and switches off the ignition to stop the engine.
- 5 Starter Grip**  
The grip of the pull starter, for starting the engine.
- 6 Carburetor Adjusting Screws**  
For tuning the carburetor.
- 7 Fuel Filler Cap**  
For closing the fuel tank.
- 8 Water Attachment**  
For connection of water supply for wet cutting.
- 9 Tensioning Nut**  
For tensioning the ribbed belt.
- 10 Adjusting Lever**  
To adjust the wheel guard in a way that sparks, dust, cutting debris or wheel fragments are directed away from the operator.
- 11 Abrasive Wheel**  
Can either be a composite abrasive wheel or a diamond abrasive wheel.
- 12 Front Thrust Washer**  
Distributes clamping pressure of mounting nut evenly over cutting wheel.
- 13 Guard**  
Guards the wheel and deflects sparks, dust, cutting debris or wheel fragments.
- 14 Muffler**  
Reduces engine exhaust noises and diverts exhaust gases away from operator.
- 15 Spark Arresting Screen**  
Designed to reduce the risk of fire.
- 16 Front Handle**  
Handlebar for the left hand of the power tool.
- 17 Decompression Valve**  
Releases compression pressure to make engine starting easier - when activated.
- 18 Cap for Spark Plug Boot**  
The spark plug boot connects the spark plug with the ignition lead.
- 19 Choke Lever**  
Eases engine starting by enriching mixture.
- 20 Fuel Pump**  
Provides additional fuel feed for a cold start.
- 21 Filter Cover**  
Covers and protects the air filter element.
- Clutch**  
Couples engine to the belt pulley when engine is accelerated beyond idle speed. (Not illustrated)

## Belt Pulley

The wheel that drives the ribbed belt and the abrasive wheel. (Not illustrated)

## Anti-Vibration System

The anti-vibration system includes a number of anti-vibration elements designed to reduce the transmission of vibrations created by the engine to the operator's hands. (Not illustrated)

**⚠ WARNING!**

The engine exhaust from this product contains chemicals known to the State of California to cause cancer, birth defects or other reproductive harm.

**⚠ WARNING!**

Some dust created by power grinding and other construction activities contains chemicals known to the State of California to cause cancer, birth defects or other reproductive harm.

Some examples of these chemicals are:

- lead from lead-based paints, and
- crystalline silica from bricks and cement and other masonry products.

Your risk from these exposures varies, depending on how often you do this type of work. To reduce your exposure to these chemicals : work in a well ventilated area, and work with approved safety equipment, such as those dust masks that are specially designed to filter out microscopic particles.

0457-186-3021

englisch USA



[www.stihl.com](http://www.stihl.com)



0457-186-3021